



Adult's and children's intuitions about artifact function.

Greta Defeyter

Email: greta.defeyter@unn.ac.uk

Background

- What information is at the core of early artifact representations, and to what extent this information changes over development (see Lawrence & Margolis, 2007).
- Several studies suggest that adult's reasoning about artifacts appears to reflect the adoption of a '**design stance**' (e.g. Dennett, 1987; Disendruck et al., 2003).

Design Stance

- An object's identity is explained in terms of its having been intentionally designed to serve a particular purpose (Dennett, 1987)
- When presented with a novel object and told that it was invented for one purpose but later used by someone else for another purpose, adults tend to judge the artifacts based on the creator's intended function.
- Researchers have therefore concluded that adults understand artifacts in terms of the design stance (German & Johnson, 2002; Hall, 1995; Kelemen, 1999; Matan & Carey, 2001).
- Debate over when the design stance develops
 - Matan & Carey: age 6
 - Defeyter & German: age 6
 - Kelemen: age 4

Conventional Use

- Children learn about artifacts through observations of how “we” use them (Tomasello, 1999).
- Costall (1995) Socialising Affordances

Pipe cleaners are also referred to as chenille stems/craft sticks. The usual length of these fuzzy creations is 12 inches.



Methods

1) Categorization Tasks (“What is it?”)

- Design function rather than current use (Hall, 1995; Kelemen, 1999, Matan & Carey, 2001).

2) Function Assignment Tasks (“What is it for?”)



Developmental changes within the core of
artifact concepts

Adee Matan^a, Susan Carey¹

*Department of Brain and Cognitive Sciences, Massachusetts Institute of Technology,
Cambridge, MA, USA*

Received 27 August 1999; received in revised form 26 January 2000; accepted 8 June 2000

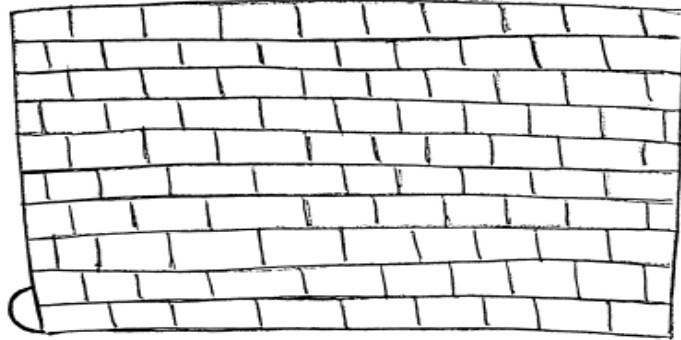

Participants told a story about a person who made an object to water flowers (the original intended function) and about another person who was using the object for making tea (the current function).

Adults: Design Stance ✓

6 year-olds: Design Stance ✓

4 Year-olds: Design Stance ✗

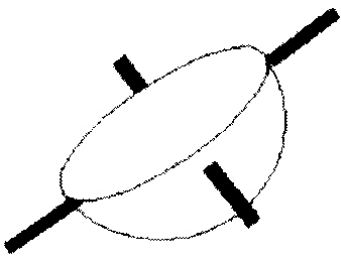

Function Judgement tasks



- Adults judge an artifact's function on the basis of the original intentions of the designer over other intentional uses and accidental activities (German & Johnson, 2002; Kelemen, 1999).
- But what about children's function judgements?

The scope of teleological thinking in preschool children

Deborah Kelemen*

Department of Psychology, 441 Moore Building, The Pennsylvania State University, University Park, Pennsylvania, PA 16802, USA

Received 20 November 1998; accepted 2 February 1999

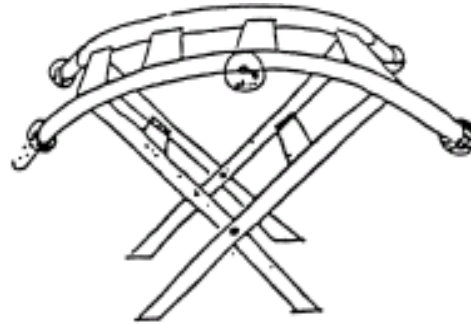

Design Function

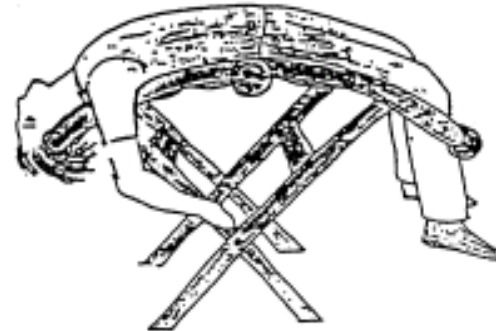

Current Function:
Accidental or
Deliberate

Adults: Design Stance ✓

5 Year-olds: Design Stance ✓

4 Year-olds: Design Stance ✓

German, T. P., & Johnson, S. C. (2002) Function and the origins of the design stance. *Journal of Cognition and Development*, 3, 279 -300.

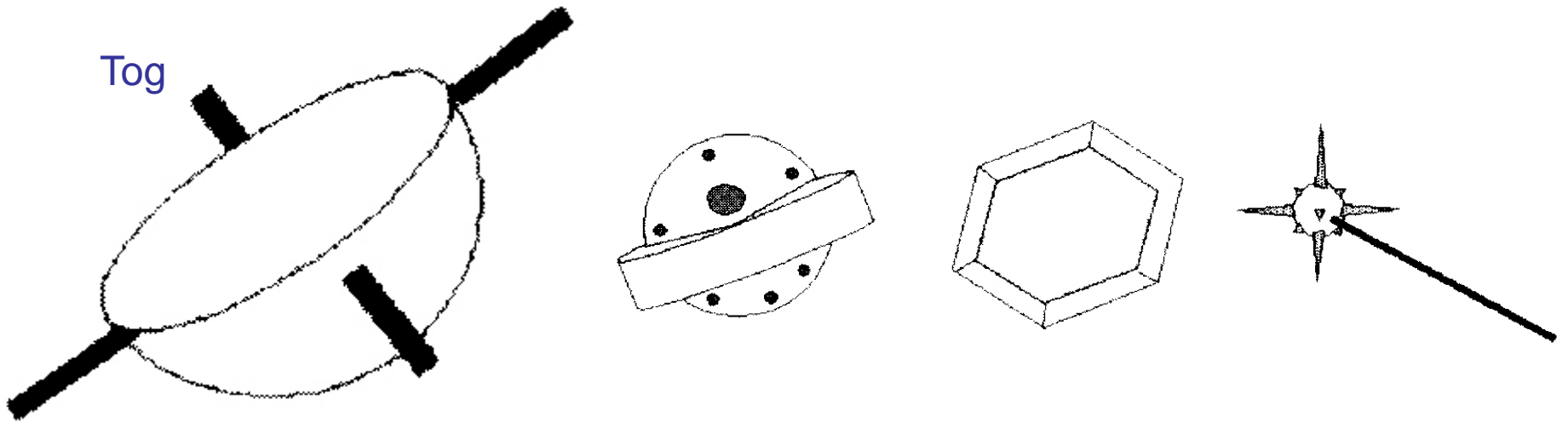

Intentional: “This is a Tog. A long time ago an inventor made the Tog to trap bugs. Now it belongs to someone else. Everyday they use it to collect raindrops.”

Accidental: “...They were carrying it along one day and guess what? They dropped it! When it landed it collected raindrops.”

- **Categorisation tasks:**
 - Matan & Carey (2001) children did not consistently rely upon design function for categorisation until age **six.**
- **Function assignment tasks:**
 - German & Johnson (2002) argue children to not give priority to the design function until age **six.**
 - Kelemen (1999; 2005) argues that children under the age of **four** give priority to design.

Categorisation of broken objects

- Kemler-Nelson et al. (2002, Study 4) found that 4 year-olds spontaneously used design function to categorise broken familiar artifacts.
- When using novel objects, children did not spontaneously rely on design function until age 10; although some evidence for 6-year-olds when probed about the design intentions.

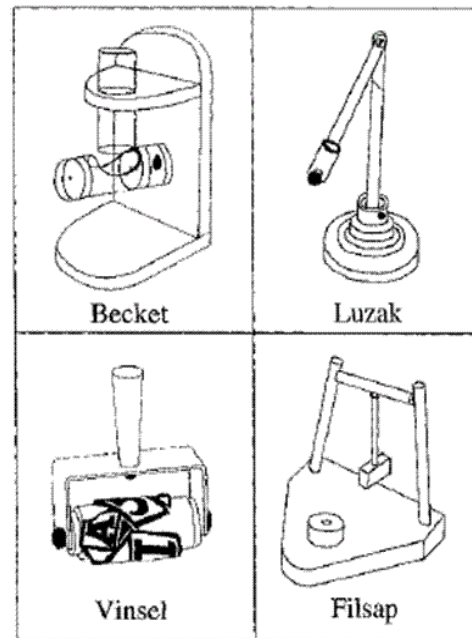

Defeyter & German (in press, Cognition)

Study 1

- In all of the preceding studies researchers have considered the design function in comparison with idiosyncratic use.
- **Two issues:**
 - Most familiar artifacts are used for the same use – the conventional use.
 - In the vast majority of cases the design function and the conventional use of an artifact match.

Aims of Study 1

- Investigate the role of design and convention in participants function judgements by manipulating the number of individuals using an artifact for an alternative function to the design function.

Predictions

- Design versus idiosyncratic use (idiosyncratic condition):
 - Adults will favour design.
 - 6-year-olds will favour design.
 - 4- year-olds ?
- Design versus conventional use (conventional condition):
 - ????

Conditions

- Participants assigned to either the Conventional condition or the idiosyncratic condition
- In the Conventional Condition: Design pitted against convention use
- In the Idiosyncratic Condition: Design pitted against idiosyncratic use
- *For each condition the presentation order of functions and the object functions were counterbalanced*

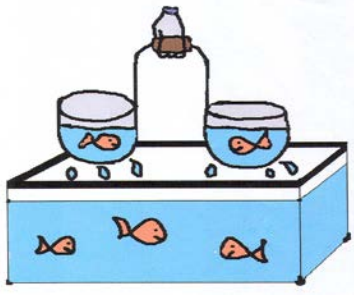

Method

- Pretest
 - 40 adults rated 15 line drawings of novel artifacts. Resulted in 4 test items.
- Participants
 - 40 undergraduate students (mean age 23 years, range 18 -25).
 - 40 4-year-olds (mean age 4-6, range 4-1 to 4-9)
 - 40 6-year-olds (mean age 6-3, range 5-7 to 6-8)

- Design versus idiosyncratic
 - In this condition design was pitted against idiosyncratic function by telling participants stories about artifacts that were designed by A for X but now used by B for Y.

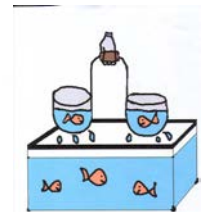
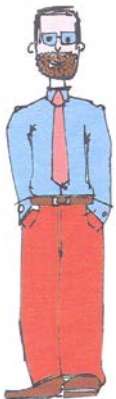
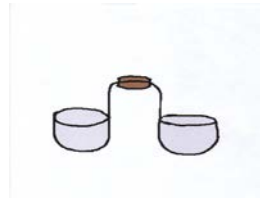

- Design vs. convention

- In this condition design was pitted against convention by telling participants stories in which novel artifacts were designed by A for X but now used by everybody for Y.

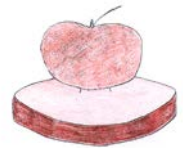
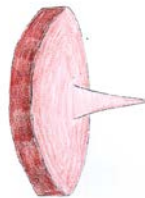

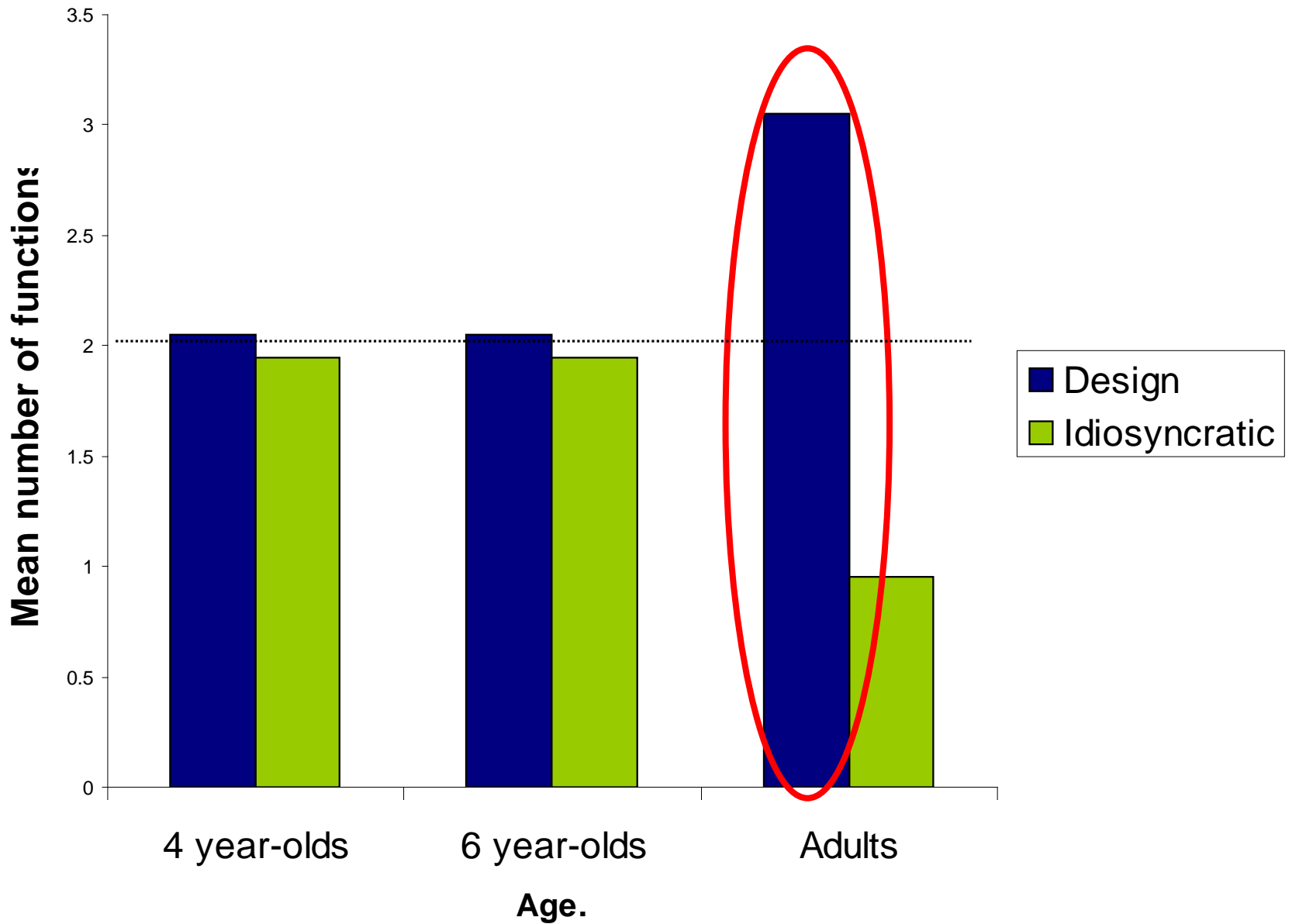

Figure 1: Mean number of design function judgements when pitted against idiosyncratic functions according to Age.

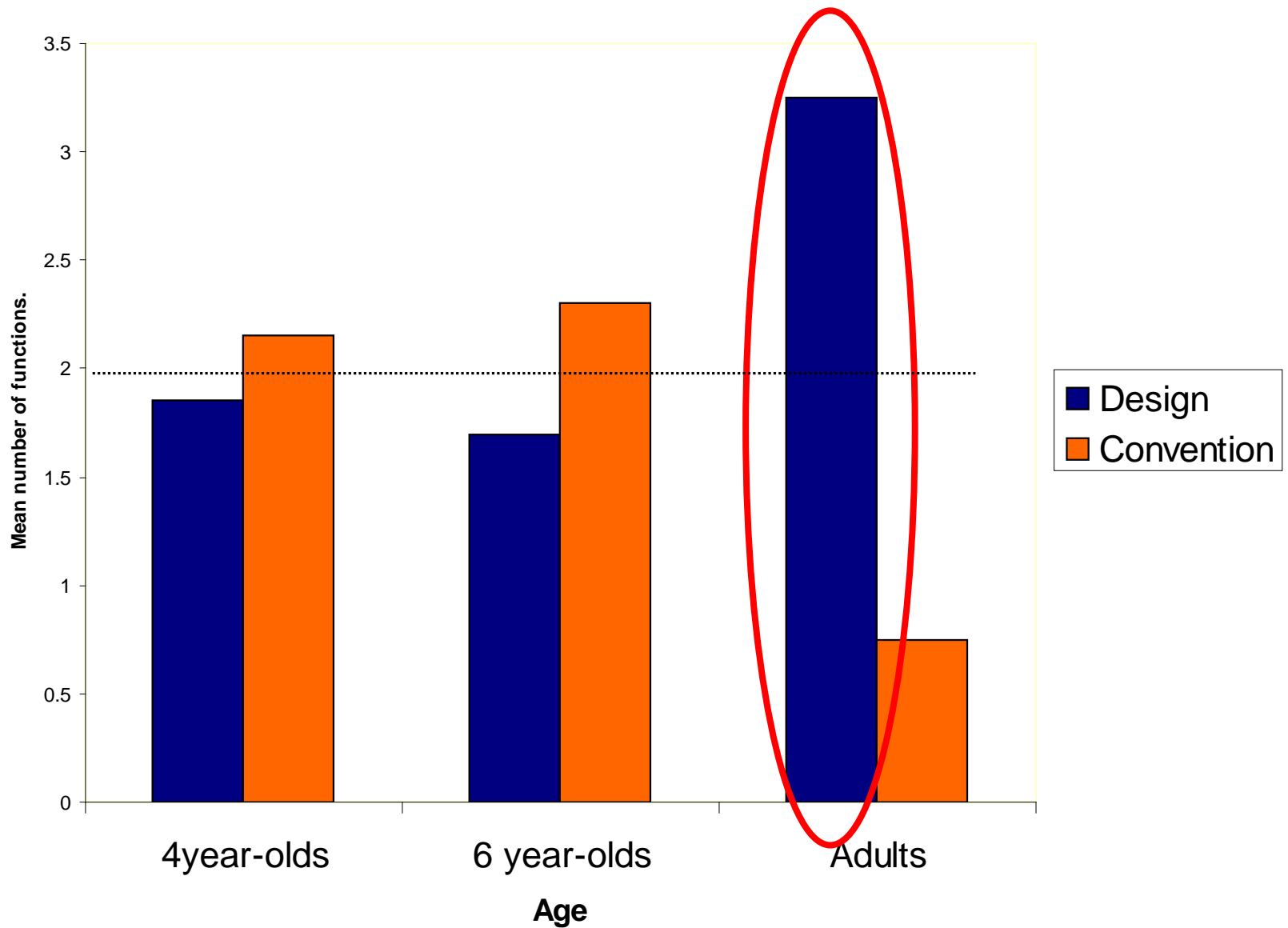
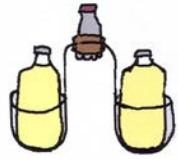
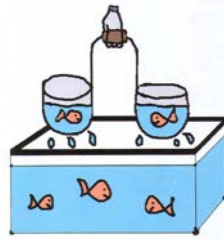

Figure 2: Mean number of design function judgements when pitted against convention according to Age.



Looking within each age group.



Adults:

- Significant preference for design over convention; $t(19) = 4.80, p < 0.001$
- Significant preference for design over idiosyncratic; $t(19) = 4.97, p < 0.001$.

4 year-olds:

- No preference for design over convention; $t(19) = 0.448, p > 0.05$.
- No preference for design over idiosyncratic use; $t(19) = 0.160, p > 0.05$.

6 year-olds:

- No preference for design over convention; $t(19) = 0.88, p > 0.05$.
- No preference for design versus idiosyncratic; $t(19) = 0.17, p > 0.05$.

Discussion

- Adults clearly weigh design over both idiosyncratic use and conventional use.
- Children: No evidence of a 'design stance'.
 - No evidence of a 'conventional stance.'
 - Did they understand the task?

The question asked: What's it really for?

- Do children understand the question?
- German & Johnson (2002).

Present study:

- Design vs. idiosyncratic - only 40% adults consistently favoured the design function over the idiosyncratic function.
- Design vs. convention - 50% adults consistently favoured the design function over the conventional function.

Study 2: Categorisation task using novel objects.

Background:

- German & Johnson (2002; study 2) pitted designer's name against another agent's name.
- Weigh designer's intent over another agent's intentional action when determining a novel artifact's category (see Bloom & Markson, 1998)
- Jaswal (2005) showed children can use makers naming rights to infer function on the basis of name.

Function Category

- But what about the opposite direction of inference?
- If children are supplied with function information alone, but asked to judge **category**, does the design category win out, even though the design **function** does not?
- We assessed this question in Study 2.

Study 2

- Aims:
 - To investigate the role of design and convention in a function categorisation task by pitting design versus idiosyncratic and design versus convention.
 - Extended German & Johnson in two ways:
 - (1) Used function based categorisation names (e.g. a fish catcher)
 - (2) Looked at younger age group.

Method

- Participants
 - 40 4-year olds (mean age 4:5)
 - 40 6-year olds (mean age 6:2)
 - 40 Adults (mean age 22:4).
-
- Materials were exactly the same as those used in Study 1. The only change was in the test question, which was changed to be a question about the object's category.

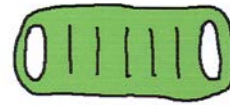
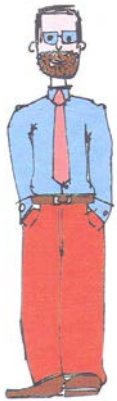

Test question: “What is it really? Is it a stick carrier or a snow slider?”

Study 2: Results

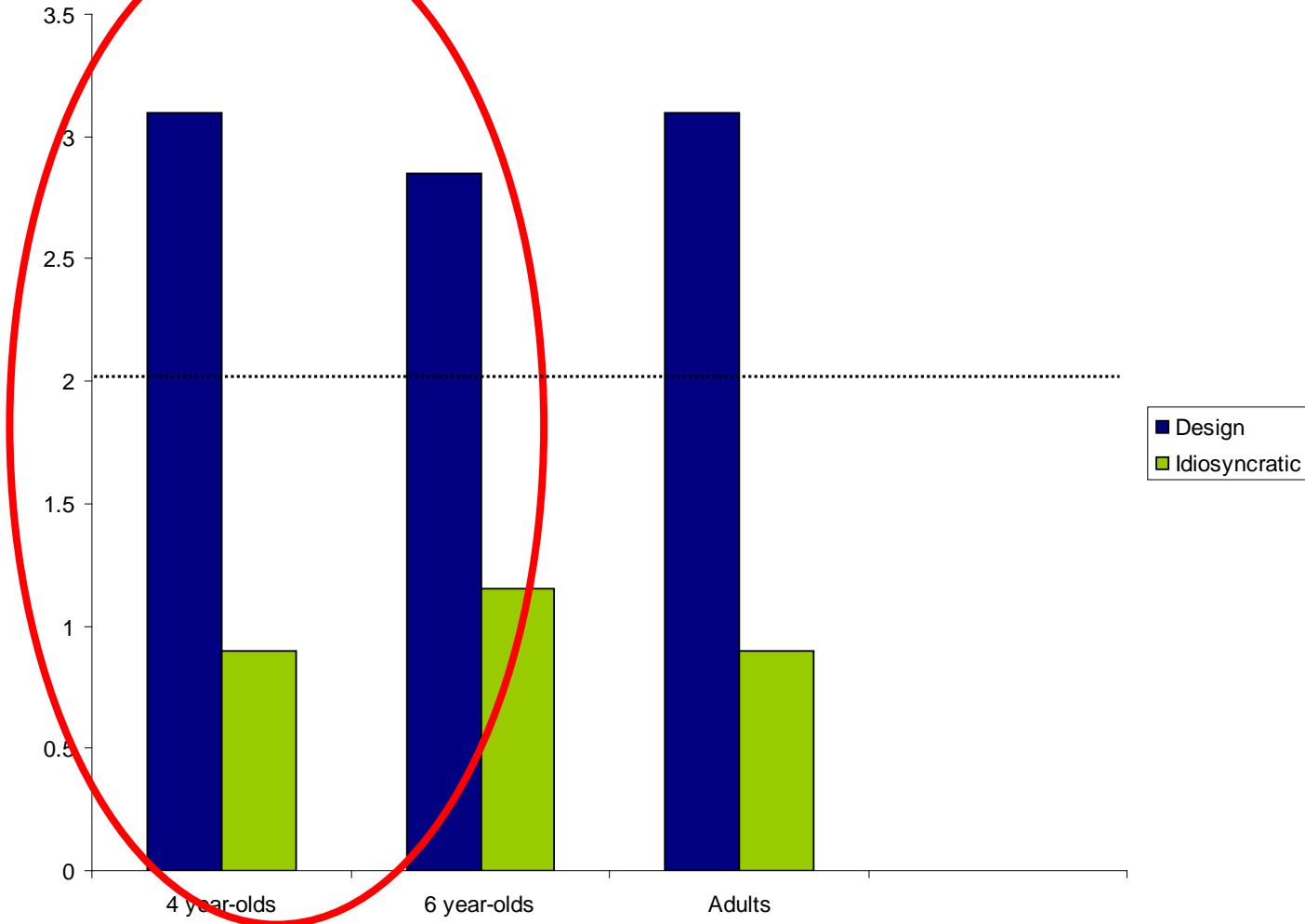

Figure 3: Mean number of design-based categorizations when pitted against idiosyncratic functions according to Age.

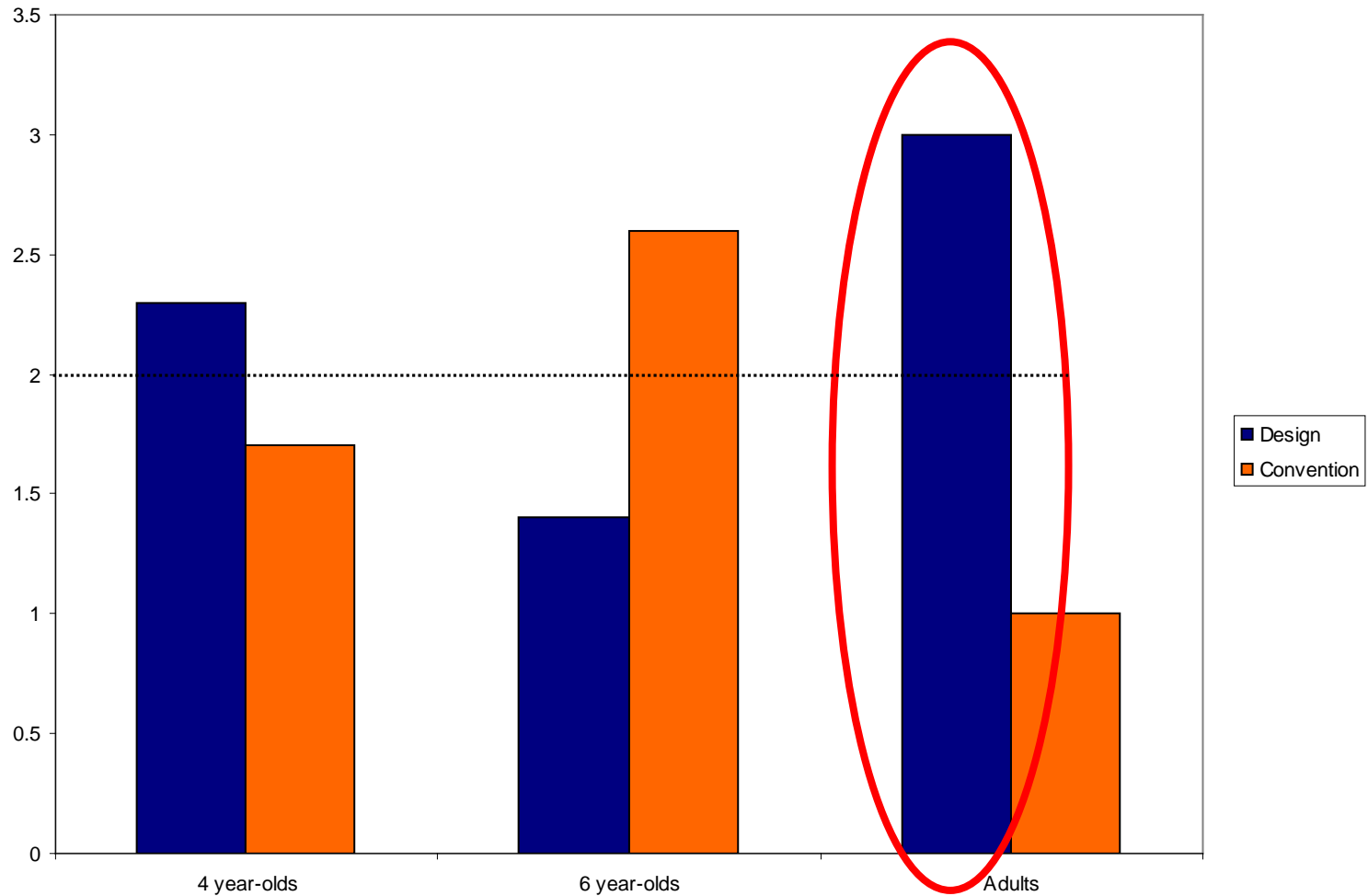

Figure 4: Mean number of design-based categorizations when pitted against conventional functions according to Age.

General Discussion

- Information about the intentions of an artifact's maker determines adults' judgements of both what function an artifact has (i.e. "what is it for?") and what category it belongs to (i.e. "what is it?") both in cases where the current alternative use is idiosyncratic and those where it is shared by everybody (but see Siegal & Callanan, 2005)
- Extends prior findings (German & Johnson, 2002; Kelemen, 1999; Kelemen & Carey, 2007; Matan & Carey, 2001)

General Discussion (Children)

- 1) Judgements of artifact function are not the same as judgements of artifact category or label
- 2) Judgements of artifact function are influenced by the current goals to which an artifact is put...
- 3) Judgements of artifact category appear to be sensitive to information about designer's intentions
- 4) Design→Category inference disrupted conventional use



- This research was funded by a grant from the British Academy to Margaret (Greta) A. Defeyter (SG-38509). Thank you to the many teachers, caregivers and children at schools and nurseries in the Newcastle upon Tyne. Many thanks to Tamsin German and Steve Avons for their creative thoughts and suggestions. Finally, many thanks to all of the research staff for their time and commitment to the project.