

## Diffusion of process improvements methods in European SMEs

### Abstract

**Purpose** – This paper evaluates the European Regions for Innovative Productivity (ERIP) project that established Innovative Productivity Centres (IPCs) to assist SMEs in the North Sea Region of Europe to develop a process improvement capability. A conceptual framework explains how a process improvement methodology developed for large firms was adapted and shaped to meet the needs of SMEs.

**Design/methodology/approach** – A comparative case study of 23 SMEs within six European countries. A protocol was developed to collect financial and operational data. This was supplemented by observations, secondary data and field notes. An established research model was used to evaluate the effectiveness and impact of the process improvement interventions.

**Findings** – The intervention context and structure of the IPCs varied by country which shaped process improvement interventions at two levels: the country and the firm. During diffusion three process improvement variants emerged that were tailored to fit the local context. Developing a process improvement capability depended upon the availability of company resources, establishing KPIs and change agent support.

**Originality/value** – The research contributes to knowledge and theory on diffusion and institutionalization by examining how SMEs responded to institutional pressures by implementing process improvement practices in different ways. Heterogeneity of both the IPCs and the external change agents were the drivers in shaping the improvement practices.

**Paper type** Research paper

**Keywords** – Process Improvement, Small-Medium Enterprise, Institutional theory, European Regions for Innovative Productivity (ERIP).

### 1 Introduction

In 2013 there were 21.6 million SMEs in the European Union's non-financial business sector which was 99.8% of the total number of companies. They employed 88.8 million people and generated €3,666 trillion of added value. SMEs accounted for 67% of total employment in the non-financial sector, but their share of value added was only 58% (Muller *et al.*, 2014). Below average productivity is "an inherent characteristic of the average SME" because they are too small to exploit economies of scale, are less capital intensive, and often employ lower qualified labour than large companies (Audretsch *et al.*, 2009, p.28). The economic importance of SMEs has encouraged governments to establish publicly funded programmes to help them adopt 'best practice' improvement methods (Done *et al.*, 2011, p.500).

There have been several British initiatives to promote process improvement at both an industry and regional level. In 1994 the Industry Forum (IF) was formed by the Society of Motor Manufacturers and Traders (SMMT) to improve the performance of the automotive supply chain (Bateman and David, 2002, p.516). Honda, Nissan and Toyota seconded Master Engineers to train IF Engineers in process improvement techniques using Master Classes (Pullin, 1998). The IF Engineers subsequently coached

change agents in participating companies using the same approach. In 2002, One NorthEast, the Regional Development Agency in North East England, established the North East Productivity Alliance (NEPA) to improve the productivity of local companies. The NEPA initiative was a development of the Master Class process, which supported regional companies in diverse sectors, in contrast to the IF initiative which focused on the automotive industry.

The European Regions for Innovative Productivity (ERIP) project began in 2008. It was match funded by the European Union's INTERREG IVB North Sea Region Programme with a total budget of €3m. One NorthEast was the Lead Partner. The project aimed to extend the NEPA methodology to assist small- and medium-sized companies in the North Sea Region of Europe (Belgium, Germany, Holland, Norway, Sweden and the UK) to develop a process improvement capability. Two levels of support were established. The first was the creation of Innovative Productivity Centres (IPCs) in each country to act as hubs for the transfer of process improvement knowledge. These comprised: a regional partner (typically a regional development agency); an academic partner; a delivery partner; and an exemplar company. The IPCs were structured and organized to suit the institutional context as well as the resources and capabilities available in each country. The second was to provide support for individual companies in each country. In total, process improvement interventions were conducted in 23 companies in six European countries. Herein lies the tension between the benefits of using a template to transfer a generic process improvement methodology to help European SMEs to become more efficient, or to adopt a principles-based approach that provides scope for local adaptation (Secchi and Camuffo, 2016).

Previous research on implementing improvement practices in SMEs has focused on implementation in a specific country (Bonavia and Marin-Garcia, 2011; Done *et al.*, 2011), and on how national institutions shape the process of diffusion of organizational practices (Cole, 1985; Guillen, 1994). There has, however, been little research on the diffusion of these practices to different organizations in other countries (Guler *et al.*, 2002, p.207), or on how differences in national contexts may impact on the performance of these practices (Volberda *et al.*, 2014, p.1259). Process improvement, continuous improvement and Lean are context dependent (Shah and Ward, 2003). Therefore, it is important to take into account contextual factors that vary by country. Firms also differ in the availability of resources and in organizational routines (Teece *et al.*, 1997). This research, therefore, considers the competing institutional tensions on both the IPCs and the SMEs that adopted the ERIP process improvement practices by addressing the following questions: First, how was the formation and configuration of regional hubs shaped by institutional factors in different European countries? Second, what impact did the interaction between the regional hubs and the individual firms have on the adoption of the process improvement methodology in an international context? Third, how did institutional factors influence the implementation of process improvement practices within individual companies? Fourth, how successful and sustainable were these interventions?

The article is organized as follows. The literature on the implementation of improvement practices in SMEs is reviewed. This is followed by a discussion of institutional theory to investigate how improvement practices could be shaped, developed and transformed during diffusion. The next section presents the research methods, data collection and analysis which is followed by the findings and discussion. A conceptual framework is presented to explain how improvement practices derived from Masters Classes and the NEPA initiative were adapted and reconfigured to create three variants

that met the requirements of SMEs in the six countries. Finally, the contribution to theory and practice and areas for further research are presented.

## **2 Implementing improvement practices in SMEs**

All types of firms have had mixed success in implementing and sustaining complex improvement practices such as Just-in-Time (White *et al.*, 1999); Total Quality Management (Kennedy and Fiss, 2009), Six-Sigma (Nonthaleerak and Hendry, 2008; Braunscheidel *et al.*, 2011) and Lean (Hofer *et al.*, 2012). Large firms are more likely than SMEs to successfully implement improvement practices (Shah and Ward, 2003, p.133). SMEs that adopt improvement initiatives find them equally effective as large companies (Adebanjo *et al.*, 2015, p.519) and anticipate reduced throughput time, higher quality, increased productivity, lower inventory levels and costs (White *et al.*, 1999, pp.7-8).

Done *et al.* (2011) identified that the best performing SMEs had, prior to a process improvement intervention, clearly communicated strategies and objectives for change, and leaders driving change who were supported by a coalition of managers and employees committed to implementing improvements. However, few firms had a performance-orientated culture; only the most successful firm in their study had key performance indicators (KPIs) in place prior to the intervention.

Kumar and Anthony (2008, p.1163) found that the main factors inhibiting the implementation of improvement initiatives were: insufficient financial, human and time resources (71.2%); lack of knowledge (59.3%); lack of training (55.9%), and internal resistance (54.2%). Managers may be unwilling to accept culture changes that promote participation and empowerment which is required to implement process improvements (Panizzolo *et al.*, 2012, p.786). Lean has not been adopted by significant numbers of SMEs because it is viewed as costly and time consuming to implement and the benefits are uncertain (Achanga *et al.*, 2006, pp.462-463; Bhamu and Sangwan, 2014, p.914). Improvement practices are not easily understood by SMEs which limits their implementation (Kumar and Anthony, 2008, p.1154). Further, companies have tended to implement improvements on an ad-hoc basis rather than as part of a planned and integrated strategy so that it becomes part of its cultural norms (Voss and Robinson, 1987; Radnor *et al.*, 2006).

There are different perspectives on how SMEs should implement improvement practices. Lee (1997, p.106) rejected an "all or nothing" approach and argued that it was feasible to implement individual elements one at a time. He maintained that total quality control, set-up time reduction, a focused factory approach, multi-skilling of employees, total preventative maintenance, small lot sizes, and Group Technology had been adopted to some degree by many SMEs. Gunasekaran *et al.* (2000) contended that JIT/Kanban, Hoshin Kanri and 5S could be applied in SMEs to achieve productivity and quality improvements. Techniques such as 5S require little capital investment. Dora *et al.* (2016, p.13) stated that a piecemeal implementation may prevent SMEs gaining the full benefit of Lean practices, but it could help to improve performance on a gradual basis. Opponents argue that Lean cannot be implemented piecemeal through the adoption of a handful of Lean tools, but requires a focus on the entire value chain (Sánchez and Pérez, 2001). This is because Lean is a philosophy which reduces the cumulative lead-time by eliminating waste (Liker, 1996, p.481). Therefore, trying to partially imitate or replicate aspects of Lean may be of little benefit.

The Master Class is a common approach used by consultants to train staff in the application of Lean tools and process improvement techniques. However, many companies have been unable to sustain

improvements made during these activities (Bateman, 2005, p.261). One reason is that the Master Class contains elements of both the template-based and principles-based approaches for transferring process improvement knowledge and practices. The method adopted by the consultant will be closer to a template-based approach if there is limited involvement from the plant management during the replication and transfer of “codified, detailed and standardized” improvement ‘best practices’ to the SME (Secchi and Camuffo, 2016, p.64). Implementation in a principles-based approach views process improvement as a learning process which is integrated into daily activities. Management and employees are proactively involved in the structuring and adaptation of these ‘best practices’ to meet local plant requirements. Process improvement initiatives are likely to fail if the emphasis is on the improvement methodology rather than the needs of the firm.

### *2.1 Process Improvement Initiatives*

The Industry Forum (IF) Master Class focuses on process rather than continuous improvement (Bateman and Rich, 2003, p.190). It comprises five stages: i) a pre-diagnostic conducted by an IF Engineer. Data are collected, and management expectations and the current performance level established. The objectives of the activity and the staff allocated are agreed; ii) after two weeks the improvement team collects and analyses the data, identifies a potential area for improvement and prioritises planned activities in a diagnostic activity; iii) after a further half-week, a check day ensures that actions required prior to the workshop are progressed and that the necessary resources are available; iv) after half-a-week, a ‘hands-on’ improvement workshop is undertaken. A team, led by an IF Engineer is responsible for proposing and making improvements. Progress and learning are assessed at the end of each day. On the final day of the week the team presents its work and a plan for future activities to management and other interested parties; v) follow-ups at monthly intervals check that the improvements made during the workshop are maintained and the targets met (Bateman, 2001; Bateman and Rich, 2003; Herron and Hicks, 2008). The Master Class has a dual purpose: to train staff in the application of Lean principles and tools; and to achieve process improvement within the workplace. The leadership of the change management process shifts from the IF Engineer to the factory improvement team as the Master Class process progresses (Bateman and Rich, 2003).

The NEPA initiative utilized the same transfer process as the IF Master Class (see Bateman, 2001), but the pre-diagnostic was modified to include three steps: i) a Productivity Needs Analysis (PNA) which identified key performance measures; ii) a Manufacturing Needs Analysis (MNA) to evaluate plant processes and select appropriate Lean tools and metrics; and iii) a Training Needs Analysis (TNA) to identify staff development requirements (Herron and Braiden, 2006). It provided a flexible approach in which tools were selected to suit the specific production environment. The NEPA initiative abstracted, transferred and applied the Master Class approach to new contexts (Lillrank, 1995).

The NEPA engineers were seconded from local ‘blue chip’ companies for two years and trained in process improvement. They were responsible for running Master Classes and training internal company change agents in large firms in the application of Lean tools. Company change agents received compulsory improvement training plus selective training in presentation skills, leadership and personal effectiveness. They were taught how to conduct process improvement interventions and were evaluated monthly on their skills and knowledge. Company change agents and operators could

achieve National Vocational Qualifications in Business Improvement Techniques through work-based training and assessment (Herron and Hicks, 2008).

In 2002 the UK Department of Trade and Industry (now the Department for Business, Innovation and Skills) established the regionally-based Manufacturing Advisory Service (MAS) to share knowledge and improve the efficiency of British industry. In October 2008 the NEPA and the MAS in North East England were merged to form the MAS-North East (MAS-NE), also known as MAS-NEPA. This combined the strengths of the NEPA and MAS approaches for transferring and implementing process improvements.

## 2.2 *The diffusion of improvement practices*

In this research, a 'new' improvement initiative is regarded as being new to the organization rather than 'state of the art' (Zbaracki, 1998; McCabe, 2002). Tolbert and Zucker (1996) viewed a management practice in three different stages: pre-institutionalization (few adopting companies and limited knowledge of the practice); semi-institutionalization (fairly diffused with some level of acceptance); and full institutionalization (an established practice). Process improvement in SMEs is somewhere between the first two stages. It has a 'fashionable' or 'fad' aspect (Abrahamson and Fairchild, 1999) rather than being widely accepted and established. As process improvement practices become institutionalized they are adopted by firms for legitimacy rather than purely for efficiency purposes (Meyer and Rowan, 1977).

DiMaggio and Powell (1983) described three institutional isomorphic change mechanisms by which firms adopt structures, programmes, policies and procedures: coercive isomorphism occurs when, for example, a powerful customer requires a supplier to adopt specific practices; mimetic isomorphism results from environmental uncertainty which leads an entity to copy the practices of more successful organizations; whilst normative isomorphism arises when organizations adopt practices to meet the requirements of professional bodies. In short, isomorphism provides legitimacy (Deephouse, 1996). Despite the insights that it provides into why certain practices are adopted, institutional theory has not been widely applied in the field of operations management (Kauppi, 2013, p.1319). There have been a limited number of studies in the discipline that have investigated the impact of institutional pressures on process improvement interventions (Boiral and Roy, 2007; Nair and Prajogo, 2009; Braunscheidel *et al.*, 2011; Heras-Saizarbitoria *et al.*, 2011).

Previous research suggests that few management practices emerge from a diffusion process unchanged (March, 1981; Czarniawska and Sevón, 2005). This is because "diffusing practices are likely to evolve during the implementation process, requiring custom adaptation, domestication, and reconfiguration to make them meaningful and suitable within specific organizational contexts" (Ansari *et al.*, 2010, pp.67-68). Herron and Hicks (2008, p.525) argued that Lean tools that have little abstraction, such as process mapping, are codified and can be easily learnt. However, complex organizational practices such as Kaizen (Brunet and New, 2003) and Quality Control Circles which have high abstraction "do not transfer very well in their original packaging" and need to be carefully adapted (Lillrank, 1995, p.988). The core ideas need to be reinterpreted and recreated to fit the local context. Many SMEs lack staff with proven knowledge of how to implement improvement practices and are therefore dependent on external expertise to implement Lean tools (Birkinshaw *et al.*, 2008, p.830; Hervas-Oliver *et al.*, 2014, p.882). Management consultants "serve as important transfer

agents” (Lillrank, 1995, p.977) and are part of the professional network which exert normative isomorphic pressures on firms to conform.

Ansari *et al.* (2010) viewed adaptation in terms of ‘fidelity’ and ‘extensiveness’. Fidelity is concerned with the scope and meaning of the practice that is being implemented and adapted and how true or distant it is from the previous version. Extensiveness assesses the degree, or scale of implementation compared to the previous version. The heterogeneity in the adoption of these improvement practices could be attributed to the contradictions between the institutional pressures and internal company practices (Heras-Saizarbitoria and Boiral, 2015, p.300). A further argument is that allowing practices to vary helps with the diffusion and implementation process in diverse international contexts (Ansari *et al.*, 2014, p.1315).

There is evidence that the adoption of an improvement practice will be affected by different cultural and international contexts. Global organizations have sought to transfer quality management and process improvement practices to their geographically dispersed subsidiaries. This has required balancing the tensions between standardization and allowing variation to meet local requirements (Ansari *et al.*, 2014, p.1333). The challenge is how to preserve fidelity by discouraging undesirable deviations from the core aspects of the practices whilst incentivising beneficial adaptations. Attempts by senior management to implement process improvement practices through coercion are likely to produce conflict and resistance especially when there is a lack of fit with cultural values. These tensions are normally resolved through rejection or the adaptation of the practice by abandoning the less useful elements (Canato *et al.*, 2013, p.1740). In some cases, the adoption of a practice may be ceremonial with a high level of implementation but a low level of internalization (Kostova and Roth, 2002, p.220).

### **3 Methods**

The European Regions for Innovative Productivity (ERIP) project was a comparative case study of 23 companies in six European countries in the North Sea Region of Europe, which is a significant number for theory development (Eisenhardt, 1989). Previous research would suggest that an improvement practice developed for large firms would probably not transfer intact from the North East of England to European SMEs as it would impact on and be shaped by local institutionalized arrangements. However, it was not obvious if any changes would occur, and if they did, what form they would take. This is because previous research has focused on the transfer of improvement practices to subsidiaries of large global companies (Kostova and Roth, 2002; Ansari *et al.*, 2014). There has been little research on how SMEs respond to the pressures for institutional isomorphism (Heras-Saizarbitoria and Boiral, 2015, p.300). It was not clear how the SMEs would manage the tension between standardization and variation such that the essence of the NEPA process improvement methodology was not lost. There is also a dearth of research on Lean implementation in SMEs which has adopted a multiple case study method (Hu *et al.*, 2015, p.988).

#### *3.1 Innovative Productivity Centres*

Karlsson and Åhlström (1997) suggested that SMEs could build unique competences by collaborating with other small firms, local universities and consultancies to create knowledge bases which add to the SMEs skills. Table 1 shows the regional, academic and delivery partners which together with an exemplar company formed IPCs as a source of process improvement knowledge and support in each

of the six regions. One of their objectives was to encourage transnational collaboration and to cascade and embed process improvement knowledge and best practice across the North Sea Region.

### **Insert Table 1 Innovative Productivity Centres in the six regions**

The regions comprised: Flanders (Belgium), Ammerland (Germany), Northern Holland, Mid-Norway, Västra Götaland (Sweden), and North East England (UK). In Belgium, Germany and Sweden the regional partner was a local/regional authority, although they were not actively involved in the project. In the UK and the Netherlands the regional development agencies were the dominant project partners. Their main interest was creating and protecting employment in their regions. SINTEF, which is the largest independent research organization in Scandinavia, specialising in technology, served a dual role in Norway as both a regional and delivery partner. The academic partners were all universities, with the exception of Sweden where it was a research institute. The delivery partners that had practical experience of implementing process improvement initiatives were universities in Belgium and Germany, the regional development agency in the Netherlands, MAS-NEPA in the UK, and research institutes in Norway and Sweden. An additional partner was the Hanseatic Parliament which took responsibility for external communication and dissemination.

The composition of each of the IPCs was determined by the political, institutional, and educational/industrial links in the six regions with some organizations, apart from in the UK, fulfilling dual roles. Therefore, the positions of power and influence within the respective IPCs varied considerably which influenced how they operated.

Experienced process improvement practitioners trained the company change agents. The ERIP approach intended to promote networking and reinforce learning by encouraging internal change agents to attend interventions at multiple sites in their respective countries as part of their training. It was envisaged that change agents in each firm would specialise in a particular Lean tool which it could then teach to the other SMEs' process improvement teams. Additionally, a trainer from MAS-NEPA in the UK with extensive experience of running NEPA Master Classes and applying the NEPA methodology held demonstration 'showcase' events in Belgium, Holland, Germany and Sweden. These events were attended by regional trainers and IPC members from the host and partner countries.

### *3.2 Recruitment of SMEs*

The SMEs were recruited through local newspaper advertisements and/or the universities' and research institutes' networks. This could be classified as an "opportunistic pattern" as the firms were able to acquire external expertise from an externally occurring opportunity as opposed to an internally recognised need (Viljamaa, 2011, p.479). In total, 23 companies fully participated in the ERIP project (see Table 2). Each of the companies was given a pseudonym to protect their identities. The companies spanned a range of manufacturing and service industries. The production systems in the majority of the companies were make-to-order (MTO) or assemble-to-order (ATO) where customer intimacy and reducing lead-times were critical to achieving competitive advantage. Five companies manufactured-to-stock (MTS). The companies were classified according to the number of employees: medium (over 200), small (51-199), mini (11-50) and micro (less than 10).

### **Insert Table 2 Companies participating in the ERIP project**

### 3.3 *Data collection and analysis*

A three stage process was adopted to collect and analyse the data during the period June 2008 to December 2012. At stage one a template was created to collect financial and operational data from each company. The data collection protocol (available on request) included specific questions relating to business objectives, contextual information, competitive profiles, financial performance, products, processes, materials, scheduling, labour, Lean tools, layout and flow, and value stream mapping. Regular site visits were conducted to observe the implementation process. Over the course of the project extensive field notes were taken during the workshops, training events, review sessions and observations and informal conversations on the shopfloor.

During stage two the researchers used the three sets of factors (shown in italics) advocated by Done *et al.* (2011) to assess the effectiveness of the process improvement interventions: (i) *intervention context* - driver of change (internal/external), recognised need for change, senior management support and established KPIs; (ii) *intervention design and implementation* – tailoring interventions, availability of personnel, availability of time, suitable composition of the team and the development of internal change agents; and (iii) *change agent approach* – the external change agent’s role, experience of running process improvement workshops; and iv) sustainability – likelihood of sustainability and access to support networks.

Qualitative and quantitative assessments were made of the impact of the improvement activities throughout the project. The researchers also adopted the rating scale devised by Done *et al.* (2011) to assess the level of process improvement after the intervention. Done *et al.* (2011) investigated best practice interventions in British SMEs, whilst this research examined interventions in a European context. A score of 1 indicated very little operational improvement compared to the pre-intervention level in the target area, no deployment of knowledge and process improvement across the firm, and no basis for sustained improvement; a score of 2 denoted limited operational improvement in the target area, little or no deployment of knowledge and process improvement, and limited scope for sustaining or continuing improvements; 3 demonstrated an average operational improvement in the target area, an average deployment of knowledge and process improvement across the SME, and a basis for sustaining and continuing improvements; 4 displayed good operational improvement in the target area, significant deployment of knowledge and process improvement across the firm, and significant potential for sustaining and continuing improvements; and 5 revealed that there has been significant operational improvement in the target area, extensive deployment of knowledge and process improvement across the SME, and considerable scope for sustaining and continuing improvements. These data for each firm were reviewed independently by two researchers working in parallel to ensure reliability and consistency and then compared. Any discrepancies were resolved by revisiting and discussing the data.

The expertise of the external change agents were ranked independently by the researchers on a scale from 1 to 5 and then compared and agreed. It was judged according to their experience of running Master Classes, or other forms of process improvement intervention and training. A score of 1 indicated little experience; 2 denoted limited experience; 3 adequate experience; 4 signified good experience; and 5 indicated significant experience and expertise.

At stage three the researchers examined how the NEPA methodology could be transferred to SMEs in Europe using either a template or principles-based approach. An important element of the analysis



was the recognition that improvement practices are often reconfigured during transfer and implementation to fit with geographical and organizational requirements.

## **4 Findings and discussion**

### *4.1 Emergence of variant process improvement methodologies*

The data revealed that the intervention context and the structure of the IPCs varied by country, which caused the NEPA methodology to be developed, shaped and transformed at two levels: the country and the firm as shown in Figure 1. There was no prescribed template of what were core or non-essential aspects of the improvement practice. The aim was to understand and explain why three different practice adaptations evolved: ERIP; ERIP-Lite; and Bite-Size, which are outlined in Figure 2 and discussed below. At the first level, the composition of the IPCs was framed by the institutional arrangements in the six countries. Each of the IPCs was subject to isomorphic pressures to implement 'best practice' process improvement methods to improve the competitiveness of SMEs in their regions. The SMEs were also subject to isomorphic pressures to improve their efficiency and competitiveness following the global recession after 2008, as many had experienced a reduction in sales.

### **Insert Figure 1 Conceptual Framework**

At the second level, the IPCs provided both normative and mimetic isomorphic mechanisms for transferring and spreading process improvement knowledge. They established links between SMEs and 'best practice' exemplar companies as well as delivering, through external change agents, customised process improvement interventions in each of the SMEs. The internal change agents were responsible for championing the diffusion throughout the companies.

### *4.2 ERIP*

This approach evolved in Belgium, Germany and Sweden. The intervention comprised: a pre-diagnostic; a diagnostic; measurement; a workshop; a yearly action plan; improvement cycles; a halfway measure; a final measure and presentation. In total the ERIP intervention comprised 16 days of activity spread over a 12 month period. During the pre-diagnostic the management selected a 'change champion' to drive process improvement in tandem with the associated internal changes. These steps took half-a-day each. A 2-day diagnostic followed using the PNA, MNA and TNA checklists. Value stream mapping was used to identify problem areas. An area was selected for the improvement cycle through an 'agenda setting dialogue' (Birkinshaw *et al.*, 2008, p.834) between the external change agent and the internal champion, and an action plan was developed with the respective supervisors and operators. Before any improvement cycle commenced, key performance indicators (KPIs) were taken as a zero-based measurement across the whole company. The six main measures were: not-right-first-time; stock turns; value added per person; cumulative lead-time; delivery schedule achievement; and downtime of equipment. Categorising added/non-value added activities, identifying waste, and conducting measurements took 1-3 days spread over one to three weeks. Two one-day workshops were held to introduce the team to process improvement concepts and Lean tools. Alternatively, the workshops could be run concurrently with the diagnostic. An action plan for the following year was an outcome of the workshop. This was followed by improvement cycles which could be repeated over a 3-6 month period to improve the processes. KPIs were reviewed monthly and comparisons could be made with other participating companies. This acted as a reinforcement mechanism to help companies maintain their momentum (Van Landeghem and April, 2011). The

delivery partner worked closely with each SME team throughout the programme, whilst the academic partner collected and evaluated KPI measurements.

## **Insert Figure 2 ERIP, ERIP-Lite and Bite-Size Methodologies**

### *4.3 ERIP-Lite*

The ERIP-Lite methodology evolved in the Netherlands where all of the interventions were conducted by the MAS-NEPA engineer who delivered process improvement training to the regional trainers and internal change agents. Each intervention took a total of 13 days spread over a year. A one-day pre-diagnostic identified the improvement objectives and associated KPIs. Two weeks later a 3-day diagnostic was held where the PNA, MNA and TNA were used to collect data, identify areas for improvement and identify the requisite Lean tools. A 'check day' was conducted to ensure that any actions, data or resources required for the workshop were available. The workshop was conducted over 5 consecutive days which aimed to achieve the objectives and targets specified by the pre-diagnostic and the diagnostic. Some partners found the PNA onerous and difficult to apply as it could take 2 days to complete. The Dutch, therefore, devised a streamlined qualitative version termed 'PNA-Lite' to identify problem areas. The improvement process cycle contained fewer checks and reviews because the emphasis was on training the internal 'change champion' rather than solely on improvement activities. The 'change champion' was responsible for initiating change within the company.

### *4.4 ERIP Bite-Size*

The Bite-Size methodology evolved from the engagement with firms in the UK and Norway which were unable to make staff available to undertake process improvement training as required by the ERIP or ERIP-Lite approaches (Powell *et al.*, 2013). The Bite-Size methodology embodied the ERIP principles: the pre-diagnostic and KPIs were identical; the diagnostic was reduced by half; and intervention activities were reduced. Check days were omitted as the external change agent and the company kept frequent contact to maintain commitment. Two days were dedicated to the workshop which was split over four half-day sessions spanning four weeks. The reporting function was the same as the ERIP methodology. Employees undertook improvement activities and reported back to the IPC team.

The Bite-Size approach provided the MAS-NEPA external change agent with the flexibility to concentrate on activities that would produce quick, short-term results. He focused on delivering productivity improvements rather than change agent training which could potentially have produced longer-term benefits to the individual and the firm (MAS, 2011, p.58).

The Norwegian IPC also developed a Bite-Size approach to assist SMEs experiencing resource constraints. It comprised a half-day pre-diagnostic, 2-day diagnostic and 3 one-day workshops.

The evidence supports Maritan and Brush (2003, p.958) who argued that an improvement methodology should be adapted to meet the characteristics of individual companies and the availability of resources. All of the methodologies demonstrated some success within the context in which they were applied. In each intervention, there was some degree of tailoring to meet the requirements of each company.

### *4.5 Process improvement outcomes*

SMEs adopting process improvement practices are engaged in "exploration, innovation and change processes" whilst also engaging in the regular daily activities to achieve their objectives (Secchi and

Camuffo, 2016, p.80). They are exploiting their existing operational capabilities whilst exploring new operational capabilities. Table 3 shows that some SMEs adopted process improvement practices extensively, whereas in other cases it was decoupled or loosely coupled with the daily activities of the plant and, therefore, had a low level of internalisation (Meyer and Rowan, 1977; Kostova and Roth, 2002). There is no evidence that the different national contexts had an impact on the process improvement outcomes.

All of the interventions with one exception (LightCo) produced some, albeit in many cases minor improvements. The data suggest that successful process improvement interventions were dependent on the following factors: a recognised need for change; senior management support; establishment of KPIs; tailoring the intervention to meet company requirements; availability of personnel; availability of time to engage with the process improvement practice; and suitable composition of the team. However, the key factor that separated the higher performing companies (with scores of 3 or 4) from those with marginal improvements (scores of 1 and 2) was that the former had all established KPIs, whilst the poorer performers failed to do so. The setting of KPIs is a necessary underpinning of any successful process improvement implementation. KPIs are linked to a company's strategy and provide the improvement team with the motivation and commitment to achieve the agreed objectives (Brunet and New, 2003).

### **Insert Table 3 Summary of Findings**

#### *4.6 Intervention context*

The stimulus for change can be categorised as external (pull factors) or internal (push factors) (Venkateswarlu and Nilakant, 2005, p.817). The drivers for change were internal champions recognising the need for change in 16 companies, and both internal and external in seven companies. Upton (1996, p.225) referred to the importance of charismatic leaders, such as the Human Resource Director at LabelCo, who are often 'obsessive' in continuously seeking improvements ('push factor'). In other cases, the intervention context was strongly influenced by the global recession after 2008 and the firms' weak financial position. Only five companies had nominal increases in sales between 2008 and 2010: three German companies, SausageCo; WholesaleCo; and TradeCo; the Dutch company LabelCo; and the British company ShoeCo. Turnover declined in the other companies. Thus the economic climate acted as a 'pull factor', or a coercive mechanism in which the senior management in many of the firms were able to create a sense of urgency for instigating change (Kotter, 1995).

Done *et al.*, (2011, p.504) found that improvement initiatives were often hampered by a lack of data. DecorCo was the only company that had established KPIs and systematically collected performance data before joining the ERIP project. The initial proposal was to measure 13 KPIs, but this was reduced to six as measuring and collecting these data proved difficult for the SMEs. The intervention teams took a pre-intervention measure followed by further measures at each intervention stage. In most cases, it proved difficult to obtain a full set of metrics across the intervention period. Only 15 companies were able to produce appropriate KPIs to support change; 13 achieved average performance improvements and two achieved good operational improvements. An analysis of the eight companies that failed to create post-intervention KPIs revealed that seven had limited improvement and one intervention failed. The research shows that establishing KPIs is an important component of the plan-do-check-act cycle which is central to process improvement initiatives.

#### 4.7 *Intervention design and implementation*

There was tailoring of the general approaches adopted by the IPCs to fit the context, i.e. the development of the ERIP, ERIP-Lite and Bite-Size methodologies. There was also tailoring of each individual intervention relating to the selection of process improvement tools to address process improvement issues. Overall, the approaches applied in Germany and Norway were more standardized than the methodologies used in the Netherlands or the UK.

The data confirmed that senior management support in conjunction with the provision of sufficient staff time for improvement activities was vital to the success of any process intervention. Four companies were unable to release staff, or provide the time for them to participate in process improvement activities: SausageCo, BottleCo, HeatCo and LightCo. However, TradeCo achieved good process improvement despite not allocating staff adequate time for these activities. This could be attributed to the buoyancy in demand for company products which consumed both personnel and time resources, but also acted as a catalyst for change. The development of the Bite-Size approach in Norway and the UK stemmed from resource limitations. Therefore, having resources available and the right composition of the improvement team was important.

The three process improvement approaches could be regarded as alternative 'Lean bundles' (Shah and Ward, 2003). The training of the change agents in ERIP and ERIP-Lite was intended to increase the companies' internal capabilities, although it was not underpinned by a vocational qualification as in the original NEPA approach. This research supports the findings of Herron and Hicks (2008, p.529) that process improvement interventions are more likely to be successfully implemented in companies with competent change agents, and that the continuity of change agents is important to develop long-term sustainability (Done *et al.*, 2011). This is because 'change champions' seek to overcome employee scepticism and build legitimacy for improvement initiatives.

In the Netherlands, the internal change agents worked with the MAS-NEPA engineer to collect data and contributed to designing, planning and delivering both teach points and change activities (MAS, 2011, p.44). Scania, an exemplar company in the Netherlands, formed a network comprising the four case SMEs plus a group of twenty SMEs to share knowledge and best practice. Scania supported the network by organizing one-day training events at its site, and by providing support, advice and guidance to sustain the momentum (MAS, 2011, p.46). This network provided a "learning laboratory" to support the interventions (Schaffer and McCreight, 2004). It demonstrated the importance of normative and mimetic isomorphic pressures in encouraging SMEs to adopt process improvement initiatives.

#### 4.8 *External change agents*

Once the SMEs had joined the ERIP project normative pressures helped promote change. This stemmed from the training provided by the MAS-NEPA engineers and the interventions conducted by the country external change agents. Braunscheidel *et al.*, (2011) similarly found that normative isomorphic mechanisms influenced the implementation of Six-Sigma. The MAS-NEPA engineers were able to provide expertise and confer moral and cognitive legitimacy on the adoption of process improvement initiatives (Birkinshaw *et al.*, 2008, p.831).

Seven showcase events were conducted by a MAS-NEPA engineer who had extensive experience of delivering process improvement training: four in the Netherlands and one each in Belgium, Germany and Sweden. The MAS-NEPA external change agent could be categorised as a process improvement

expert (Block, 2000) in his role of delivering showcase events. These sessions were conducted in English (and translated into the local language) using training materials prepared by One NorthEast. This presented few problems as many managers and shopfloor workers had a reasonable command of English. Further, the training utilized visual diagrams and symbols to illustrate points which could be readily understood in any language.

The regional trainers/external change agents from the partner countries also attended these events. Their role was that of a process consultant in helping the SMEs to diagnose their problems and to jointly create a solution (Schein, 1988, p.11). These trainers adapted the methodology to meet local requirements. For example, the Belgian and Swedish trainers' approach was "more akin to teaching than training – in the form of a series of shorter instruction sessions rather than a more intense, hands-on 'learning-by-doing' approach" (MAS, 2011, p.16). In Germany, the external change agent drew on his previous experience as a Lean specialist at Boeing to instigate "a more rigorous or mechanistic" approach. Internal champions were trained to use various tools derived from the teach points. Support was provided by regular reviews and visits from the trainer. At ShoeCo, the MAS-NEPA engineer acted as an expert to deliver and shape the Bite-Size methodology. In Norway, the external change agents took on a doctor-patient role in their Bite-Size methodology to help the management teams to diagnose their process problems.

The data in Table 3 suggest that all three roles played by the external change agents were equally effective in producing short-term improvements. All of the external change agents had at least adequate experience. Above this level, the skill, knowledge and expertise of the external change agents did not appear to improve the intervention outcomes. Apart from the Bite-Size approaches used in Norway and the UK, the aim was to build-up the process improvement capabilities within the companies to enable them to continue to implement further process improvements.

#### *4.9 Sustainability*

This research has identified some of the contextual conditions together with the capabilities and resources required to implement process improvements. Nine of the 23 SMEs had the capability to embed a continuous improvement philosophy, but only two of the firms would be able to do this without external support. This supports the findings of Done et al. (2011) that SMEs require ongoing support in order to develop and sustain a process improvement capability.

Access to process improvement assistance was dependent on the sustainability of the IPCs. The IPC in Germany was strongly based in the local university and did not continue beyond the lifespan of the project. In the Netherlands, the regional development agency and the network formed by Scania played a pivotal role in the initiative. The continuing support of these organizations makes it more likely that improvements and networks will be sustained. The Norwegian and Swedish IPCs have as their bedrock the two applied research institutes, SINTEF and Swerea respectively, to provide ongoing process improvement support and maintain these networks. In Belgium a spin out company from Ghent University called Veliton was formed to implement the ERIP methodology throughout the country. The companies in the UK and Norway are less likely to sustain process improvements as the Bite-Size approach did not develop internal change agents, so these companies would require external support. In the UK, with the abolition of the regional development agency, there is now no formal body to coordinate process improvement activities.

## 5 Contribution to theory and practice and future research

This research adds to knowledge and theory on diffusion and institutionalization by examining how SMEs responded to institutional pressures by implementing process improvement practices in different ways. In doing so, we responded to the call for operations management researchers to adopt institutional theory to provide alternative perspectives to that of economic rationality for exploring the adoption of strategies and practices (Kauppi, 2013). Previous research on why some organizations bow to institutional pressures has focused mainly on large organizations rather than SMEs (Heras-Saizarbitoria and Boiral, 2015, p.300).

The conceptual framework presented in Figure 1 shows how the NEPA methodology was transferred to SMEs in Europe and how the heterogeneity in adoption was shaped within the IPC and at the level of the firm. In this particular case there was no hierarchical control over the diffusion and adoption process unlike corporate mandates from multinational corporations to subsidiaries (Kostova and Roth, 2002). The research builds on previous work by Ansari et al. (2010) and Ansari et al. (2014) to show that by allowing a process improvement methodology to vary and to be adapted to fit the local context assisted the diffusion process in the six countries. Further research is required on how different environmental factors and national contexts shape and impact on SMEs' decisions to adopt process improvement practices.

There was no evidence of any competing or incompatible logics in terms of the policy objectives of the IPCs, which was also a reflection of how they were constituted. The heterogeneity of the six IPCs and their constituent partners had a major influence on the type of improvement practice that was adopted as opposed to firm size (Smets *et al.*, 2012, p.900). Governmental institutions adopted policies to improve SMEs' competitiveness in order to protect jobs. Employees were similarly concerned with job security. This exerted coercive pressures on the IPCs to develop process improvement interventions to support these policy objectives. Information on the ERIP initiative, the 'showcase' events and related training, and visits to exemplar companies also applied mimetic and normative pressures on the IPCs to copy best practices. This helped to create a favourable institutional environment as the interests of all of the stakeholders were aligned (Kostova and Roth, 2002, p.218).

The IPCs and the country external change agents exerted both mimetic and normative isomorphic pressures on the SMEs to implement process improvements. At the level of the firm, there was little evidence of coercive isomorphic pressures from customers or investors to adopt process improvements. Nevertheless, the SMEs precarious trading and financial positions after the financial crisis of 2008 played a major role in encouraging the pursuit of efficiency. There was no suggestion that the management or employees viewed the implementation of process improvements as externally imposed and therefore coercive. For managers, this would indicate that the conditions favourable to implementing process improvement is when the external institutional context is supported by the active agency of the SMEs in providing appropriate support and resources including establishing KPIs (summarized in Table 3). Managers are then able to decide whether they wish to develop a process improvement capability through the ongoing training of internal change agents, or rely upon external change agents to solve immediate operational problems.

External change agents tend to adopt incremental initiatives that they have observed working well elsewhere (Mol and Birkinshaw, 2014, pp.1305-1306). The emergence of the three ERIP variants could be attributed to the heterogeneity of the change agents engaged in delivering process improvement.

They had different work experiences and training which did impact on how they implemented process improvements in the companies. This may be partly explained by the dominant position of the delivery partner and its desire to pursue a single process improvement methodology. At the local level the external change agent was able to tailor the interventions to meet individual SME requirements which had a normative impact on the implementation process.

Although the skill and expertise of the external change agent was crucial in stimulating engagement with process improvement, it was not a major contributory factor in its successful implementation. There was no evidence that the external change agent in the role of expert was more effective than that of the process consultant or the doctor-patient relationship. It is surprising to note that the level of experience of the external change agent did not have a major impact on performance outcomes, although all of the change agents had adequate experience. This has relevance for both managers and process improvement practitioners who are seeking to construct a process improvement strategy. One explanation is that the external change agents involved the employees in the implementation which prevented a decoupling between the process improvement and internal practices (Heras-Saizarbitoria and Boiral, 2015, p.307). In other words, a principles-driven approach to implement process improvement is more likely to create the conditions for learning through experimentation and self-discovery compared to a template-driven approach where there is little local involvement in the process (Secchi and Camuffo, 2016, pp.78-79). Future research could compare the effectiveness of those improvement initiatives which involve employee participation with those based on coercive approaches.

The fidelity of the NEPA methodology was preserved in ERIP and ERIP-Lite. However, the Bite-Size approach had low fidelity as it excluded training and development for internal change agents. A prescriptive template approach would not have satisfied the requirements of resource-constrained SMEs, and without local adaptation managers would have been discouraged from pursuing process improvements. Further research is required on how managers and internal and external change agents decide on the degree of fidelity in the adaptation process. The adaptation was low-extensiveness as a limited range of Lean tools were applied in focused areas with in most cases limited roll-out.

One of the limitations of this study was that it was conducted during a period when the actions of the SMEs were conditioned by the global recession and its aftermath. There was a strong imperative to reduce costs and improve processes. Nevertheless, the variation in commitment to process improvement as indicated by resource allocation and outcomes could lead to a reduction in commitment, or abandonment during more prosperous periods (Younkin, 2016). The strength of the initial adoption or trends in the performance of the KPIs may be indicators of whether it is maintained or abandoned. Further research is required on how many of these SMEs have sustained these improvement practices.

## References

Abrahamson, E. and Fairchild, G. (1999) 'Management fashion: Lifecycles, triggers, and collective learning processes', *Administrative Science Quarterly*, 44(4), pp. 708-740.

Achanga, P., Shebab, E., Roy, R. and Nelder, G. (2006) 'Critical success factors for lean implementation within SME's', *Journal of Manufacturing Technology Management*, 17(4), pp. 460-471.

Adebanjo, D., Tickle, M., Laosirihongthong, T. and Mann, R. (2015) 'A study of the use of business improvement initiatives: the association with company size and the level of national development', *Production Planning & Control*, 26(7), pp. 507-524.

Ansari, S.M., Fiss, P.C. and Zajac, Z.J. (2010) 'Made to fit: How practices vary as they diffuse', *Academy of Management Review*, 35(1), pp. 67-92.

Ansari, S.M., Reinecke, J. and Spaan, A. (2014) 'How are practices made to vary? Managing practice adaptation in a multinational corporation', *Organization Studies*, 35(9), pp. 1313-1341.

Audretsch, D., van der Horst, R., Kwaak, T. and Thurik, R. (2009) *First Section of the Annual Report on EU Small and Medium-sized Enterprises, Report Commissioned by the European Commission Director General Enterprise and Industry*. The Netherlands: EIM Business & Policy Research.

Bateman, N. (2001) *Sustainability, a guide to process improvement*. Cardiff: Lean Enterprise Research Centre, Cardiff Business School.

Bateman, N. (2005) 'Sustainability: the elusive element of process improvement', *International Journal of Operations & Production Management*, 25(3-4), pp. 261-276.

Bateman, N. and David, A. (2002) 'Process improvement programmes: a model for assessing sustainability', *International Journal of Operations & Production Management* 22, 22(5), pp. 515-526.

Bateman, N. and Rich, N. (2003) 'Companies' perceptions of inhibitors and enablers for process improvement activities', *International Journal of Operations & Production Management*, 23(2), pp. 185-199.

Bhamu, J. and Sangwan, K.S. (2014) 'Lean manufacturing: literature review and research issues', *International Journal of Operations & Production Management*, 34(7), pp. 876-940.

Birkinshaw, J., Hamel, G. and Mol, M.J. (2008) 'Management innovation', *Academy of Management Review*, 33(4), pp. 825-845.

Block, P. (2000) *Flawless Consulting: A Guide to Getting Your Expertise Used*. 2nd edn. Austin, Texas: Learning Concepts.

Boiral, O. and Roy, M.J. (2007) 'ISO 9000: integration rationales and organizational impacts', *International Journal of Operations & Production Management*, 27(2), pp. 226-247.

Bonavia, T. and Marin-Garcia, J.A. (2011) 'Integrating human resource management into lean production and their impact on organizational performance', *International Journal of Manpower*, 32(8), pp. 923-938.

Braunscheidel, M.J., Hamister, J.W., Suresh, N.C. and Star, H. (2011) 'An institutional theory perspective on Six Sigma adoption', *International Journal of Operations & Production Management*, 31(4), pp. 423-451.

Brunet, A.P. and New, S. (2003) 'Kaizen in Japan: an empirical study', *International Journal of Operations & Production Management*, 23(12), pp. 1426-1446.

Canato, A., Ravasi, D. and Phillips, N. (2013) 'Coerced practice implementation in cases of low cultural fit: cultural change and practice adaptation during the implementation of six sigma at 3M', *Academy of Management Journal*, 56(6), pp. 1724-1753.

Cole, R.E. (1985) 'The macropolitics of organizational change: A comparative analysis of the spread of small group activities', *Administrative Science Quarterly*, 30(4), pp. 560-585.

Czarniawska, B. and Sevón, G. (2005) 'Translation is a vehicle, imitation is a motor, and fashion sits at the wheel', in Czarniawska, B. and Sevón, G. (eds.) *Global Ideas: How Ideas, Objects and Practices Travell in the Global Economy*. Copenhagen: Liber and Copenhagen Business School Press, pp. 7-12.

Deephouse, D.L. (1996) 'Does isomorphism legitimate?', *Academy of Management Journal*, 39(4), pp. 1024-1039.

DiMaggio, P.J. and Powell, W.W. (1983) 'The iron cage revisited: Institutional isomorphism and collective rationality in organizational fields', *American Sociological Review*, 48(2), pp. 147-160.

Done, A., Voss, C. and Rytter, N.G. (2011) 'Best practice interventions: short-term impact and long-term outcomes', *Journal of Operations Management*, 29(5), pp. 500-513.



- Dora, M., Kumar, M. and Gellynck, C. (2016) 'Determinants and barriers to lean implementation in food processing SMEs - a multiple case analysis', *Production Planning & Control*, 27(1), pp. 1-23.
- Eisenhardt, K.M. (1989) 'Building theories from case study research', *Academy of Management Review*, 14(4), pp. 532-550.
- Guillen, M.F. (1994) *Models of Management: Work, Authority, and Organization in a Comparative Perspective*. Chicago: University of Chicago Press.
- Guler, I., Guillén, M.F., Muir, J. and Macpherson (2002) 'Global competition, institutions, and the diffusion of organizational practices: The international spread of ISO 9000 quality certificates', *Administrative Science Quarterly*, 47(2), pp. 207-232.
- Gunasekaran, A., Forker, L. and Kobu, B. (2000) 'Improving operations performance in a small company: A case study', *International Journal of Operations and Production Management*, 20(3), pp. 316-336.
- Heras-Saizarbitoria, I. and Boiral, O. (2015) 'Symbolic adoption of ISO 9000 in small and medium-sized enterprises: the role of internal contingencies', *International Small Business Journal*, 33(3), pp. 299-320.
- Heras-Saizarbitoria, I., Landín, G.A. and Molina-Azorín, J.F. (2011) 'Do drivers matter for the benefits of ISO 14001?', *International Journal of Operations & Production Management*, 31(2), pp. 192-216.
- Herron, C. and Braiden, P.M. (2006) 'A methodology for developing sustainable quantifiable productivity improvement in manufacturing companies', *International Journal of Production Economics*, 104(1), pp. 143-153.
- Herron, C. and Hicks, C. (2008) 'The transfer of selected Lean manufacturing techniques from Japanese automotive manufacturing into general manufacturing (UK) through change agents', *Robotics and Computer-Integrated Manufacturing*, 24(4), pp. 524-531.
- Hervas-Oliver, J.-L., Sempere-Ripoll, F. and Boronat-Moll, C. (2014) 'Process innovation strategy in SMEs, organizational innovation and performance: a misleading debate?', *Small Business Economics*, 43(4), pp. 873-886.
- Hofer, C., Eroglu, C. and Hofer, A.R. (2012) 'The effect of lean production on financial performance: the mediating role of inventory leanness', *International Journal of Production Economics*, 138(2), pp. 242-253.
- Hu, Q., Mason, R., Williams, S.J. and Found, P. (2015) 'Lean implementation within SMEs: a literature review', *Journal of Manufacturing Technology Management*, 26(7), pp. 980-1012.
- Karlsson, C. and Åhlström, P. (1997) 'A lean and global smaller firm', *International Journal of Operations & Production Management*, 17(10), pp. 940-952.
- Kauppi, K. (2013) 'Extending the use of institutional theory in operations and supply chain management research', *International Journal of Operations & Production Management*, 33(10), pp. 1318-1345.
- Kennedy, M. and Fiss, P. (2009) 'Institutionalization, framing and diffusion: the logic of TQM adoption and implementation decisions among U.S. hospitals', *Academy of Management Journal*, 52(5), pp. 897-918.
- Kostova, T. and Roth, K. (2002) 'Adoption of an organizational practice by subsidiaries of multinational corporations: institutional and relational effects', *Academy of Management Journal*, 45(1), pp. 215-233.
- Kotter, J.P. (1995) 'Leading change: why transformation efforts fail', *Harvard Business Review*, 73(2), pp. 59-67.
- Kumar, M. and Anthony, J. (2008) 'Comparing the quality management practices in UK SMEs', *Industrial Management & Data Systems*, 108(9), pp. 1153-1166.
- Lee, C.Y. (1997) 'JIT adoption by small manufacturers in Korea', *Journal of Small Business Management*, 35(3), pp. 98-107.
- Liker, J.K. (1996) *Becoming Lean* New York: Free Press.
- Lillrank, P. (1995) 'The Transfer of Management Innovations from Japan', *Organization Studies*, 16(6), pp. 971-989.

- March, J.G. (1981) 'Footnotes to organizational change', *Administrative Science Quarterly*, 26(4), pp. 563-577.
- Maritan, C.A. and Brush, T.H. (2003) 'Heterogeneity and transferring practices: Implementing flow manufacturing in multiple plants', *Strategic Management Journal*, 24, pp. 945-959.
- MAS (2011) *Report for ERIP: Findings From Testing a Change Agent Lean Productivity Improvement Methodology in Small and Medium Size Enterprises in North East England*. Sunderland: The Manufacturing Advisory Service North East.
- McCabe, D. (2002) 'Waiting for dead men's shoes': Towards a cultural understanding of management innovation', *Human Relations*, 55(5), pp. 505-536.
- Meyer, J.W. and Rowan, B. (1977) 'Institutionalized organizations: Formal structure as myth and ceremony', *American Journal of Sociology*, 83(2), pp. 340-363.
- Mol, M.J. and Birkinshaw, J. (2014) 'The role of external involvement in the creation of management innovations', *Organization Studies*, 35(9), pp. 1287-1312.
- Muller, P., Gagliardi, D., Caliandro, C., Bohn, N. and Klitou, D. (2014) *Annual Report on European SMEs 2013/2014 - A Partial and Fragile Recovery*. Brussels: European Commission.
- Nair, A. and Prajogo, D. (2009) 'Internalisation of ISO 9000 standards: the antecedent role of functionalist and institutionalist drivers and performance implications', *International Journal of Production Research*, 47(16), pp. 4545-4568.
- Nonthaleerak, P. and Hendry, L. (2008) 'Exploring the six sigma phenomenon using multiple case study evidence', *International Journal of Operations & Production Management*, 28(3), pp. 279-303.
- Panizzolo, P., Garengo, P., Sharma, M.K. and Gore, A. (2012) 'Lean manufacturing in developing countries: evidence from Indian SMEs', *Production Planning & Control*, 23(10-11), pp. 769-788.
- Powell, D., Hicks, C., McGovern, T. and Small, A. (2013) 'A bitesize Lean change methodology for small and medium-sized enterprises', *Lean Management Journal*, 5(3), pp. 7-11.
- Pullin, J. (1998) 'Master class', *Automotive Engineer*, 23(7), p. 66.
- Radnor, Z., Walley, P., Stephens, A. and Bucci, G. (2006) *Evaluation of the Lean Approach to Business Management and its use in the Public Sector*. Scottish Executive Social Research.
- Sánchez, A.M. and Pérez, M.P. (2001) 'Lean indicators and manufacturing strategies', *International Journal of Operations and Production Management*, 21(11), pp. 1433-1451.
- Schaffer, R.H. and McCreight, M.K. (2004) 'Build your own Change Model', *Business Horizons*, 47(3), pp. 33-38.
- Schein, E. (1988) *Process Consultation, Volume 1: Its Role in Organizational Development*. Reading, MA: Addison-Wesley.
- Secchi, R. and Camuffo, A. (2016) 'Rolling out lean production systems: a knowledge-based perspective', *International Journal of Operations & Production Management*, 36(1), pp. 61-85.
- Shah, R. and Ward, P.T. (2003) 'Lean manufacturing: context, practice bundles, and performance', *Journal of Operations Management*, 21(2), pp. 129-149.
- Smets, M., Morris, T.I.M. and Greenwood, R. (2012) 'From practice to field: A multilevel model of practice-driven institutional change', *Academy of Management Journal*, 55(4), pp. 877-904.
- Teece, D., Pisano, G. and Shuen, A. (1997) 'Dynamic capabilities and strategic management', *Strategic Management Journal*, 18(7), pp. 509-533.
- Tolbert, P.S. and Zucker, L.G. (1996) 'The institutionalization of institutional theory', in Clegg, S.R., Hardy, C. and Nord, W.R. (eds.) *Handbook of Organization Studies*. Thousand Oaks California: Sage, pp. 175-190.
- Upton, D. (1996) 'Mechanisms for building and sustaining operations improvement', *European Management Journal*, 14(3), pp. 215-228.
- Van Landeghem, H. and April, J. (2011) 'People driven productivity: lean for small businesses', *Management Services*, pp. 13-18.
- Venkateswarlu, P. and Nilakant, V. (2005) 'Adoption and persistence of TQM programmes - case studies of five New Zealand organizations', *Total Quality Management*, 16(7), pp. 807-825.

- Viljamaa, A. (2011) 'Exploring small manufacturing firms' process of accessing external expertise', *International Small Business Journal*, 29(5), pp. 472-488.
- Volberda, H.W., van den Bosch, F.A.J. and Mihalache, O.R. (2014) 'Advancing management innovation: synthesizing processes, levels of analysis, and change agents', *Organization Studies*, 35(9), pp. 1245-1264.
- Voss, C.A. and Robinson, S.J. (1987) 'Application of just-in-time manufacturing techniques in the United Kingdom', *International Journal of Operations and Production Management*, 7(4), pp. 46-52.
- White, R.E., Pearson, J.N. and Wilson, J.R. (1999) 'JIT manufacturing: a survey of implementation in small and large U.S. manufacturers', *Management Science*, 45(1), pp. 1-15.
- Younkin, P. (2016) 'Complicating abandonment: how a multi-stage theory of abandonment clarifies the evolution of an adopted practice', *Organization Studies*, 37, pp. 1-37.
- Zbaracki, M.J. (1998) 'The rhetoric and reality of total quality management', *Administrative Science Quarterly*, 43(3), pp. 602-636.

Region / Country	Regional Partner	Academic Partner	Delivery Partner	Exemplar Company
Flanders (Belgium)	Vlaams Agentschap Ondernemen	Ghent University	Ghent University	Daikin Europe (air conditioning/ refrigeration)
Ammerland (Germany)	Ammerland	University of Applied Science Osnabrück	University of Applied Science Osnabrück	Airbus (aerospace); Meyer Werft (Ship yard); Premium Aerotec (aerospace)
Northern Netherlands	N.V. NOM	Groningen University	N.V. NOM	Scania (heavy trucks); Philips (domestic appliances)
Mid - Norway	SINTEF	Norwegian University of Science and Technology	SINTEF	Teeness Sandvik Coromant (anti-vibration tools); Benteler Automotive (aluminium products)
Västra Götaland (Sweden)	Västra Götaland	Swerea IVF	Swerea IVF	Atlet (material handling)
North East England (UK)	One NorthEast	Newcastle University Business School	MAS-NEPA	Nissan (automotive)

Table 1 Innovative Productivity Centres in the six regions

Company	Industry	Sales 2010 (€ million)	MTO/MTS/ ATO	Employees	Company Classification
<b>Germany</b>					
SausageCo	Meat	24.0	MTO	240	Medium
WholesaleCo	Wholesale	15.0	N/A	10	Micro
MetalCo	Metal Producer	N/A	MTO	70	Small
PrintCo	Printing	5.5	MTO	73	Small
WindowCo	Window Manufacturer	12.4	MTO	122	Small
TradeCo	Trading Company	28.4	N/A	64	Small
<b>Holland</b>					
BoatliftCo	Boat lift systems	7.4	MTO	69	Small
HeatCo	Heating Equipment	15.4	MTO/MTS	95	Small
PotatoCo	Planting & storage equipment	20.5	MTO	93	Small
LabelCo	Label Printing	17.8	MTO	120	Small
<b>Sweden</b>					
GraphicCo	Printing	11.7	MTO	51	Small
TechnoCo	Rectifier technolog	15.2	MTO	78	Small
GlazingCo	Window Manufacturer	10.3	MTO	69	Small
<b>Belgium</b>					
SheetMetalCo	Sheet Metal Processing	6.9	MTS	60	Small
DécorCo	Décor Business	18.2	MTS	28	Mini
AssembleCo	Production/ Assembly lines	1.5	MTS	9	Micro
FurnitureCo	Furniture Supplier	6.2	MTO	50	Mini
<b>Norway</b>					
CircuitCo	Electronic products	6.5	ATO	55	Small
LightCo	Lighting/ heating controls	5.1	ATO	83	Small
StairCo	Wooden stairs	16.3	MTO	123	Small
ElectronicsCo	Electronics	8.9	ATO	50	Mini
MouldCo	Injection Moulding	12.3	MTS	76	Small
<b>UK</b>					
ShoeCo	Orthotic & Medical	12.6	MTO	227	Medium

Table 2 Companies participating in the ERIP project

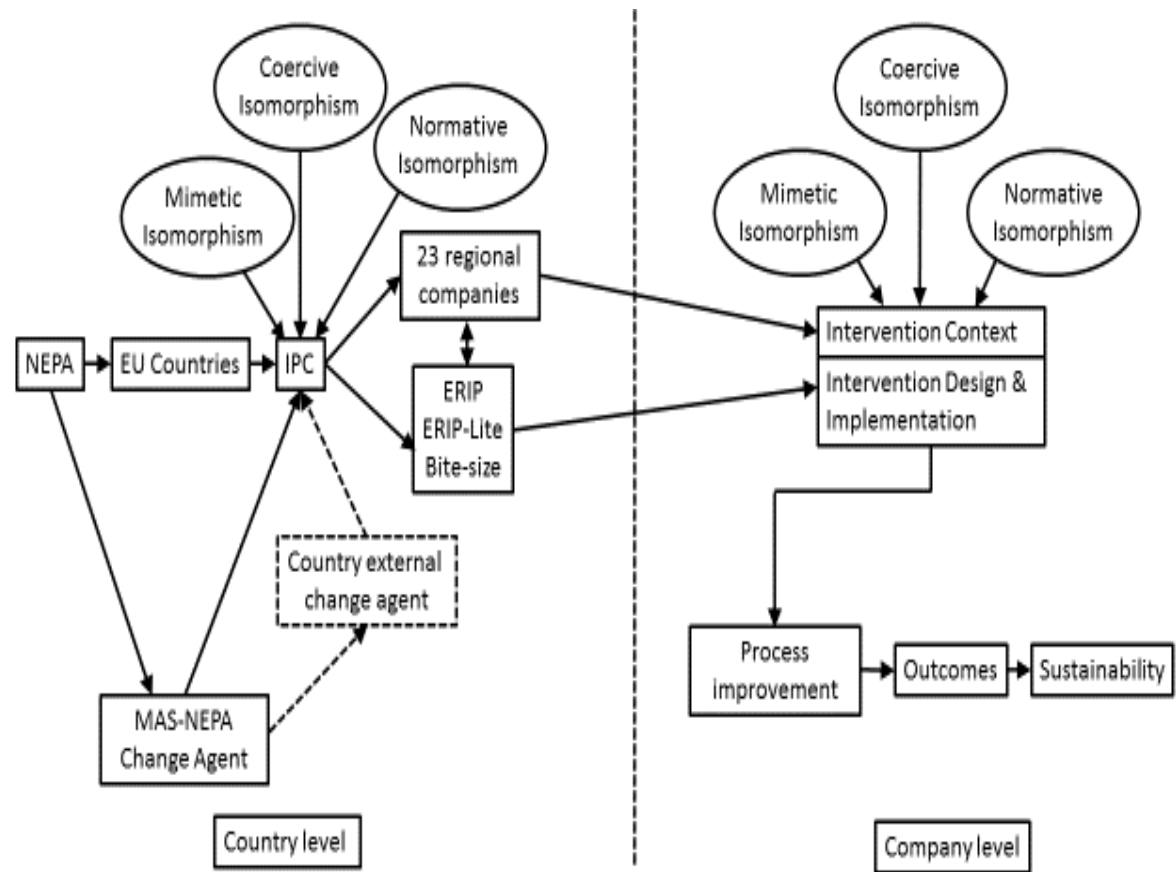

Figure 1 Conceptual Framework

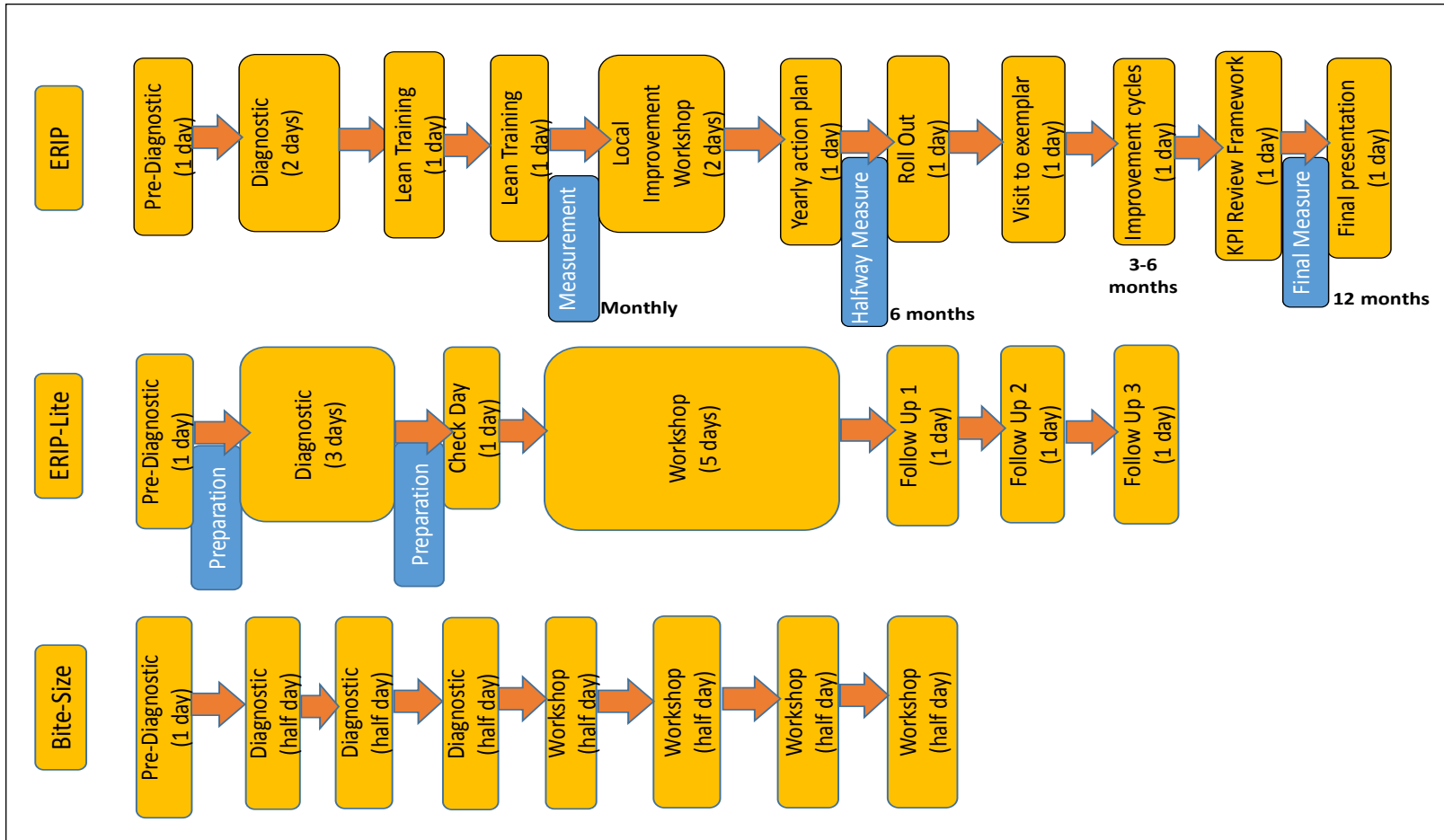

Figure 2 ERIP, ERIP-Lite and Bite-Size Methodologies